

Satron VCK

Optical Total Lignin Content Transmitter

The VC family of transmitters measures process parameters by transmitting strobes of light into the pulp and measuring the back-scatter characteristics. Measurement values are calibrated by sampling and laboratory analysis of process.

The SATRON VCK is a multichannel optical transmitter, suitable for total content and consistency measurement (fiber and filtrate) in majority of the Bleach plant applications.



PRODUCT CERTIFICATIONS

European Directive Information:

Electro Magnetic Compatibility EMC directive (2014/30/EU) including latest amendments with the application of the harmonized standards:

EN 61326-1:2013

Low Voltage Directive (2014/35/EU) including latest amendments with the application of harmonized standards:

EN 61010-1:2010

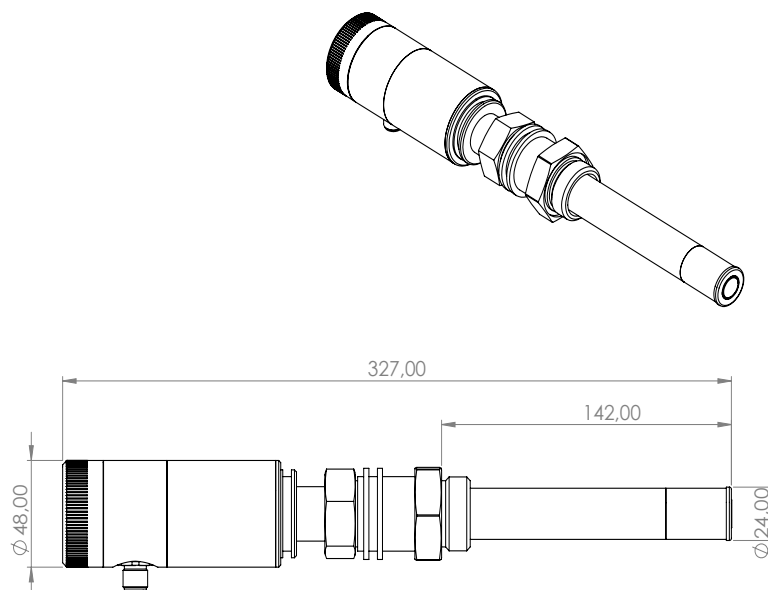

Standard VCK sensor. All dimension in the datasheet are in millimeters (mm).

Probe options

Standard measuring probe

(Selection code option 0)*

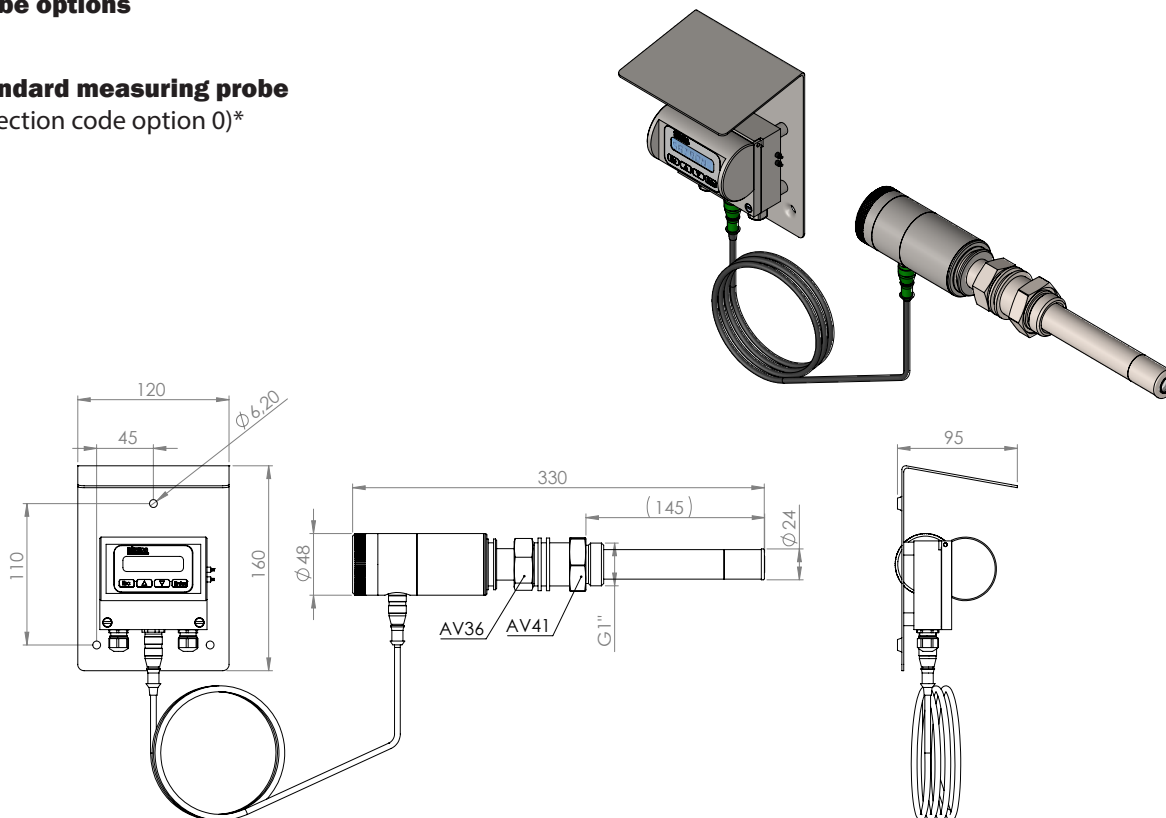

Remote measuring probe, IP68

(Selection code option R)*

Remote measuring probe is recommended in mounting places where high vibration or high humidity may affect the measuring electronics.

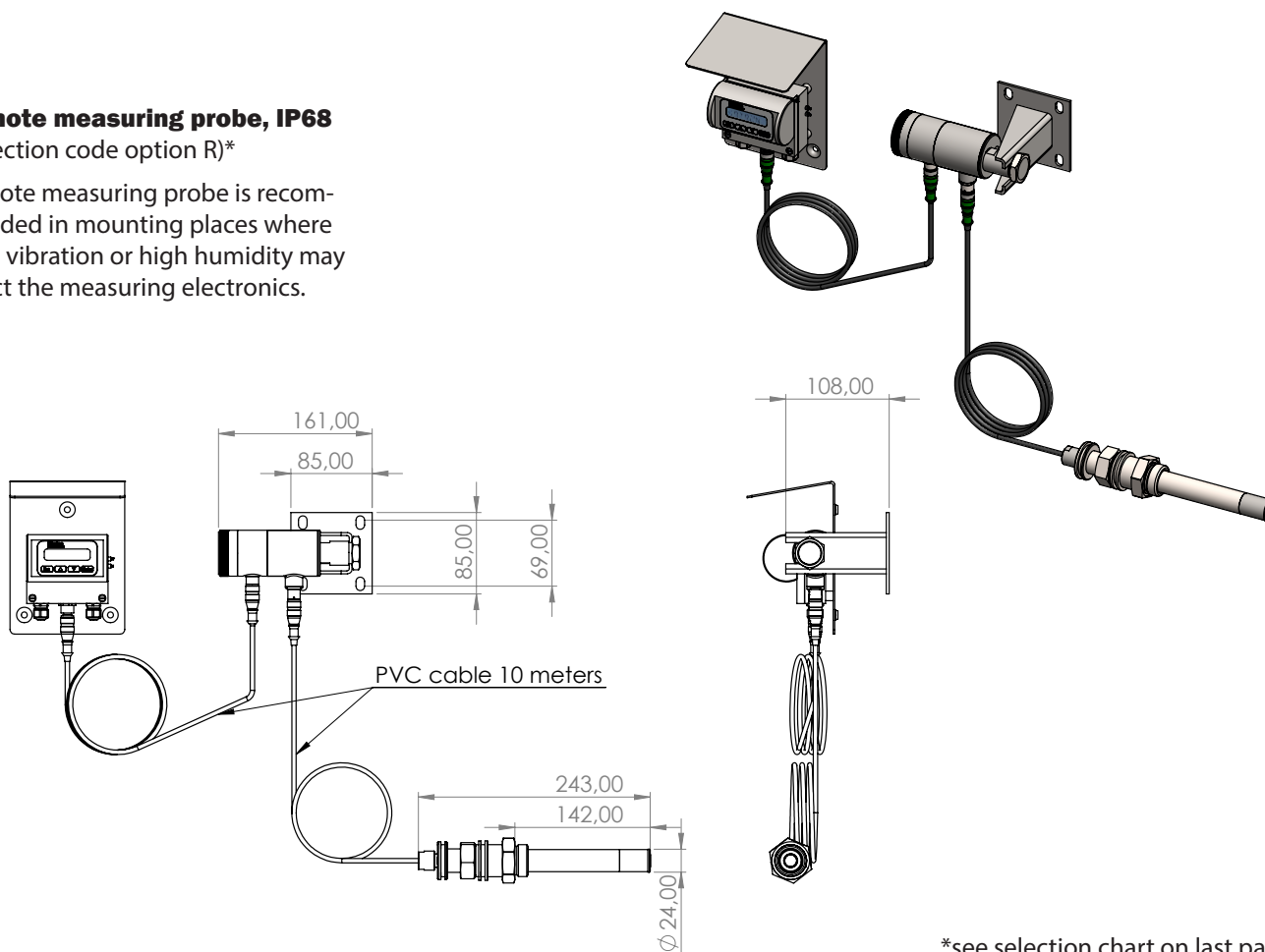

*see selection chart on last page

Remote Display Unit

The Remote Display Unit (RDU) provides a local display of the measured values and serves also as a simple menu-driven calibration and troubleshooting interface. The RDU includes two analog 4-20 mA outputs, three dry contact binary inputs and three contact outputs.

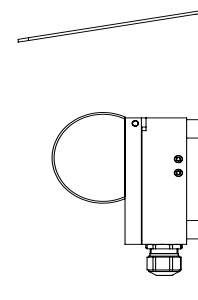
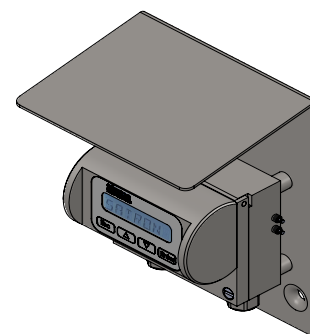
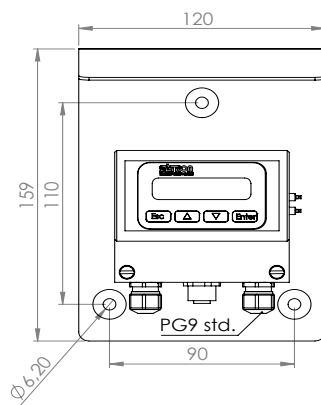

Device enclosure options

Connection Box (K)

Remote electronics in the device enclosure. External sample switch mounted on the right face of the cabinet. Power supply 115/230 V 50/60 Hz, code K. Compatible with housing type L and probe type R with display.

Product code: M1325065

Connection Box (KF)

Remote electronics in the device enclosure with flushing valve. Flushing valve installed under the cabinet. External sample switch mounted on the right face of the cabinet. Power supply 115/230 V 50/60 Hz, code K. Compatible with housing type L and probe type R with display.

Product code: M1050193

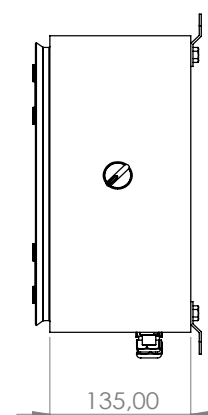
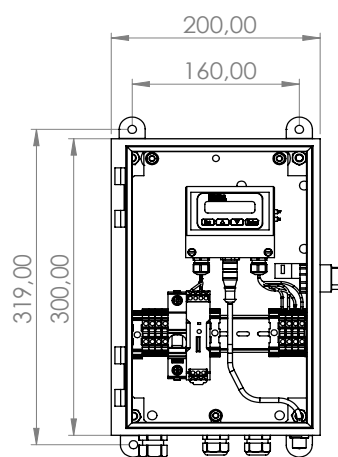
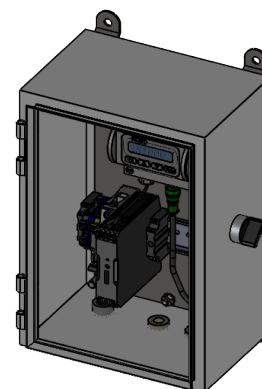

Flushing coupling for option KF

Product code: M1050102

PROCESS CONNECTIONS

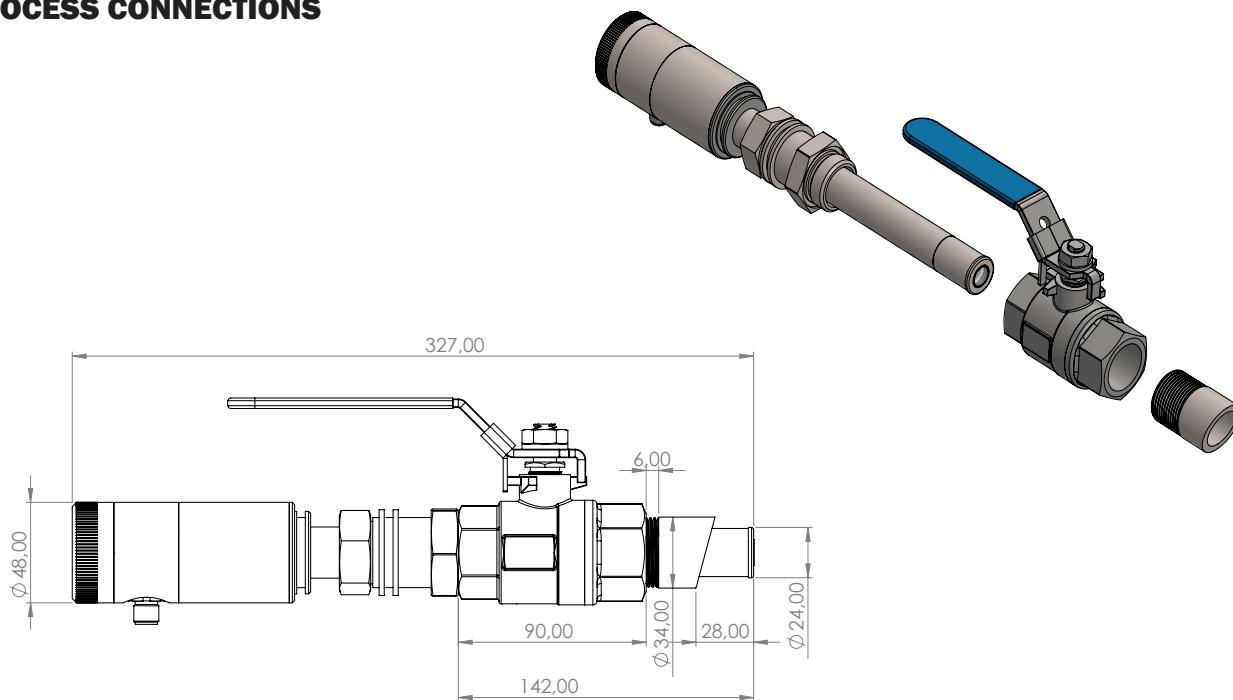

Standard model: VCK with process connection G1A ball valve insertion, G1 15° coupling, wetted parts material AISI316L, PG9 connection. Dimensions in millimeters. Selection code option B1. Coupling not included.

Installation

The location of the transmitter should be on the high-pressure discharge of the pump in the turbulent flow. The optimal location is on a 45-degree angle off the centerline of the discharge

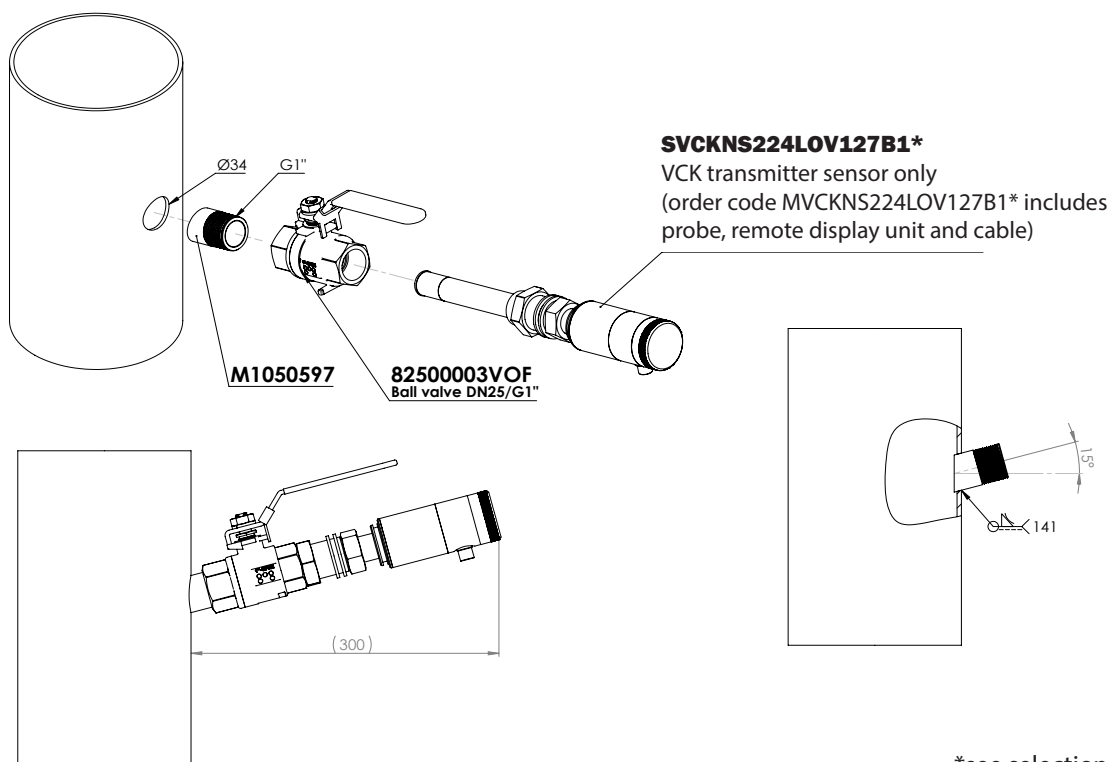

*see selection chart on last page

Installation of the flushing coupling

Product code for flushing coupling: M1050597

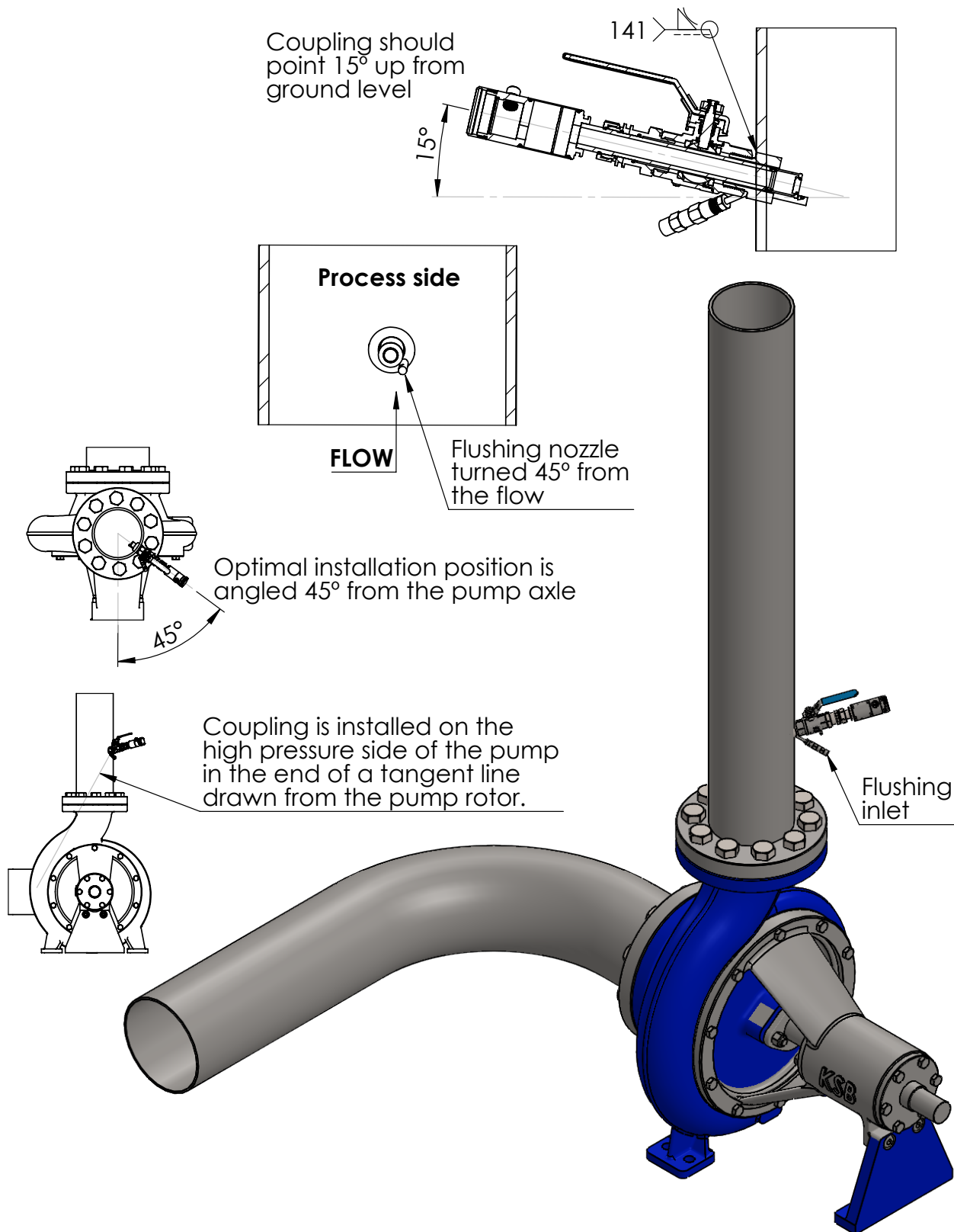

SATRON VCK Optical Total Lignin Content Transmitter

PASVE® Cs compatibility

VCK is compatible with the PASVE® Cs mounting and service valve to enable safe removal of the optical consistency transmitter from the process without stopping the process or without draining the tank. (Selection code option P1, valve sold separately)

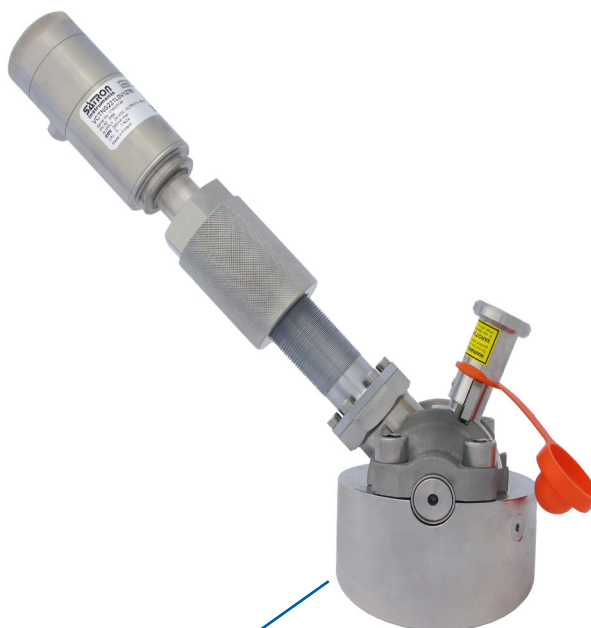

PASVE® Cs
Product code: MCSB240MD00Z4

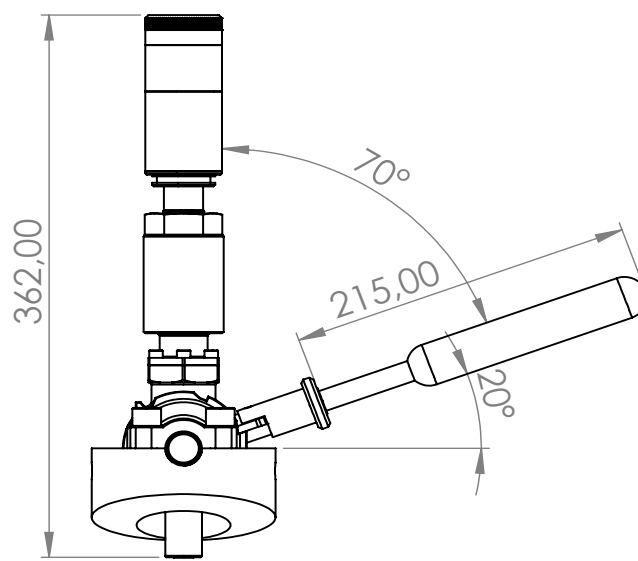
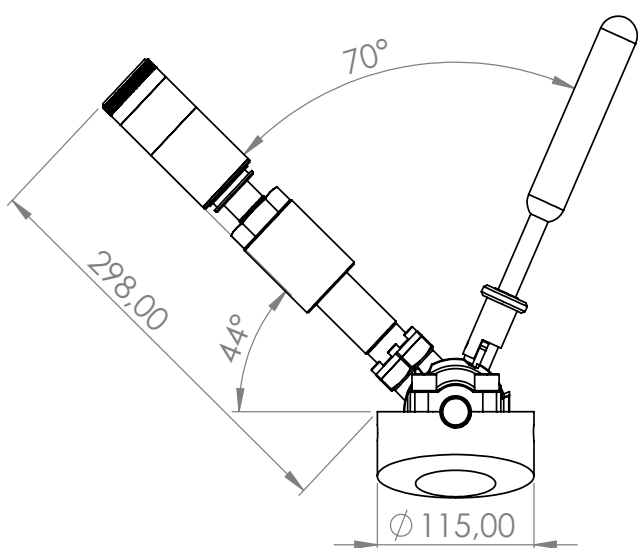

Service position:

Sensor removal
Sensor cleaning

Measuring position



TECHNICAL SPECIFICATIONS

Measuring range and span

See Selection Chart.

Measurement accuracy

Measurement accuracy is determined by the accuracy of the laboratory analysis results.

Zero and Span adjustment

Available, can be made by using keyboard (display option)

Damping

Time constant is continuously adjustable 0.01 to 60 s. Factory setting 0,5s.

Repeatability

0.01% Cs.

Temperature limits

Ambient: -30 to +80 °C

Process: 0 to + 140 °C

Shipping and storage: -40 to +80 °C.

Output

1st mA loop & powering:

3-wire (3W), 4-20 mA

2nd mA loop:

2-wire, 4-20 mA

Supply voltage and permissible load

Sensor: 24VDC

Device enclosures option K:

115/230VAC

Humidity limits

0-100 % RH

EMC directive

2014/30/EC - EN 61326-1:2013

CONSTRUCTION

Materials:

Sensing element 1): AISI316L (EN 1.4404), or Titanium Gr2.

Sapphire lens, Coupling 1): AISI316L (EN 1.4404), Duplex (EN 1.4462), Hast. C276 (EN 2.4819) or Titanium Gr2

Pressure class:

PN25

Connection hose between sensing element and housing

Codes **L** and **R** : PVC signal cable or hose protected with PTFE/AISI316 braiding

Device enclosure, code **K**:

EN 1.4301 (AISI304)

Calibration

Precalibrated at the factory for 0-7%Cs range. Final calibration against laboratory measurements with actual sample after installation is required.

Electrical connections

Remote electronics housing with display code **L**:

PG9 gland for cable; Conductor cross section solid:

max 2.5 mm²

Conductor cross section flexible:

max 1.5 mm²

Device enclosures (with display), code **K**:

- PG13,5 inlet, 3 pcs

- M12 plug connector for the sensor signal.

I/O-connections

bout1-3

Relay, grounding contact

Maximum voltage 35 V

Maximum current 50 mA

Maximum leakage current 10 µA

bin1-3

NC (no connection) OFF

0...2 V ON

Minimum values for switch in use

Voltage 16 V

Current 4 mA

Leakage current 1 mA

Current output1

Range 3.5...23 mA

Maximum load 600 Ω

Factory setting 4...20 mA

Current output2

Internal power supply

Current output 2 has same ground as binary IO

Maximum load 400 Ω

Range 3.5...23 mA

Factory setting 4...20 mA

External power supply Current output 2 is galvanically isolated

Maximum supply voltage 35 VDC

Range 3.5...23 mA

Factory setting 4...20 mA

Maximum isolation voltage 100 VDC

Process connections

- With G1 connecting thread

- Through ball valve or PASVE®, see selection chart.

Protection class:

See Selection chart.

Weight

Housing with M12

Remote Housing (**L**): 2.9 kg

Remote sensor (**R**): 2.9 kg

Device enclosure (**K**) 6,2 kg

SPARE-PARTS

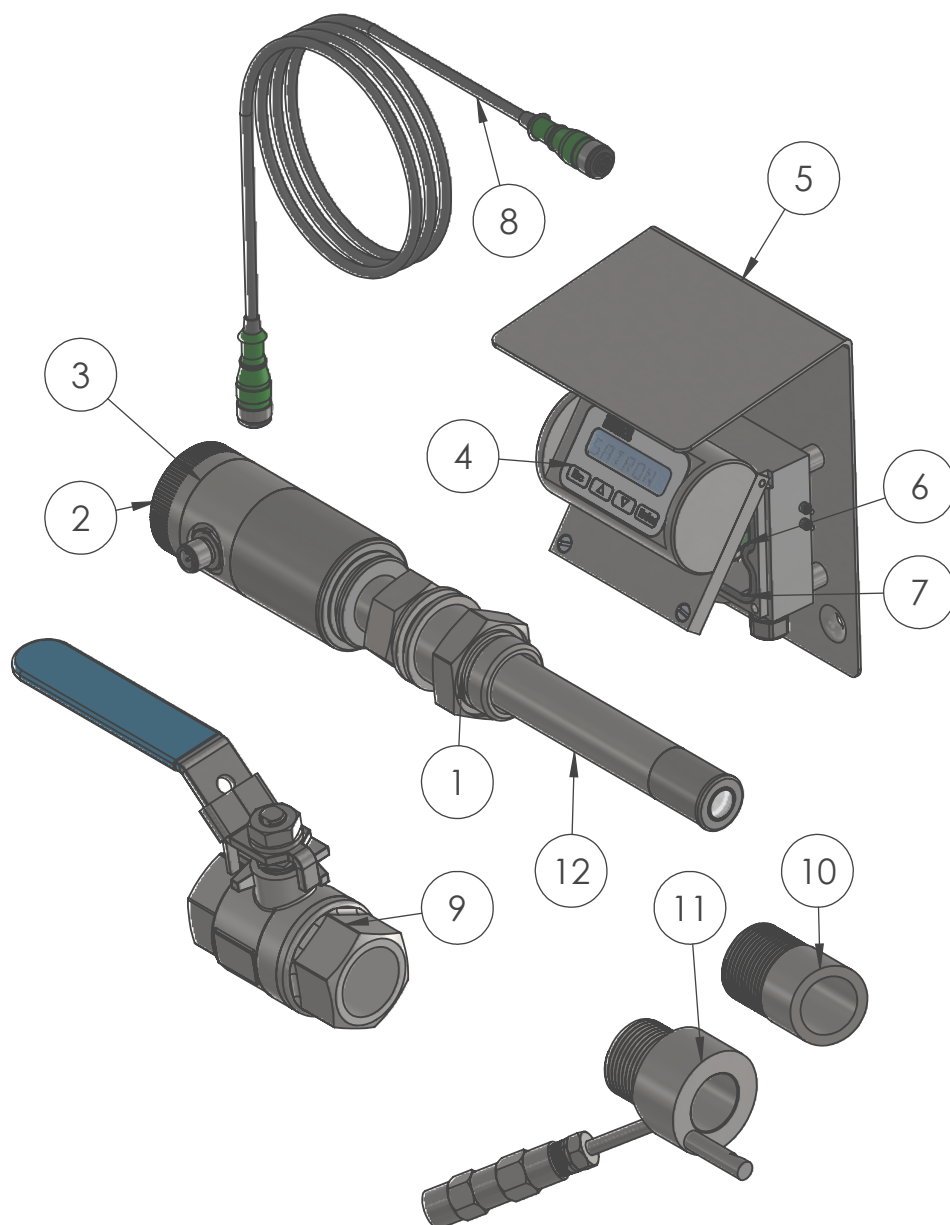

No	Part name	Order code
1.	O-ring EPDM	80036203
2.	O-ring	80013800
3.	AISI 316 cover	T1300256
4.	Sticker	T1325215
5.	Remote Display Unit RDU	T1325016
6.	Fuse for L-Housing	74212000
7.	Seal for L-Housing display	80017226
8.	L-Housing data cable (Standard 15 meters)	70000451 (10m extension male-female cable 70000600)
9.	AISI 316L ball valve	82500003
10.	G1 15° coupling for ball valve	M1050597
11.	Flushing coupling G1 for process connection B1	M1050102
12.	VCK transmitter sensor	For sensor only change order code M to S, example: MVCKNS224L0V127B1 -> SVCKNS224L0V127B1

